



ANNUAL REPORT | 2018



SJA vision is a society free from poverty, hunger and all forms of discrimination based on gender, creed or ethnicity.

SJA's mission is to establish a well-organized community by accommodating socially excluded population with healthy, literate individuals who are both motivated and empowered to improve their socio-economic status. SJA deals with people in distress, who are poverty stricken, socio-economically marginalized, illiterate, disables, discriminated due to gender, creed, ethnicity and thereby excluded especially women and children.

Goal of SJA is to empowerment of the poor through uplifting their socio-economic status and establishing healthy and environmentally soundsociety.

Table of Content

Message from Executive Director

01

SJA: An Overview

02

Geographical Presence

03

Project Accomplished in 2018

04-53

Audit Report of 2018

54-57

Message from Executive Director

It gives me great pleasure to present the Annual Report of Sylhet Jubo Academy (SJA) for the year 2018 to all the members, well-wishers, partner and the donors of the organization.

SJA started its long journey from the year 1991 with sincerity and strong commitment to bring the positive change in the life of the poor and marginalized community of Bangladesh. Throughout its journey SJA congregated adequate experience in the vast arena of human development with innovation, remarkable expansion under which undoubtedly lies the team efforts, team building process, hard work dedicated human resource along with accountability in the implementation process of activities, projects and programs.

SJA successfully accomplished the year 2018 with mitigation of so many challenges through its innovation and problem solving mechanism which is shown in this yearly report of 2018.

On behalf of the organization I would like to take the opportunity to express our profound thanks and gratitude to all our past and present well-wishers, supporters, Donors, the Government of Bangladesh, partner organization, our community level stakeholders, members of the General and Executive Committee who have extended and have been extending continuous support to SJA. I also express my warmest wishes to all my colleagues and all staff members and volunteers and especially those who put their endeavors in this report.

I do confidently believe that with the support and cooperation of our valuable stakeholders, donors, partner, devoted and dynamic employees and above all the prudent and expert guidance of General and Executive committee, SJA will achieve full long term sustainability both operationally and financially, and continued to improve and expand services to its target population.

A H M Faisal Ahmed
Executive Director



SJA: An Overview

Sylhet Jubo Academy (SJA) was established in August 1991 by a small group of philanthropists, led by former United Nations Volunteer (under UNDP, Nepal) A H M Faisal Ahmed. Their aim was to develop a locally based, not-for-profit and non-political development organisation that would operate at a grassroots level to address the real needs of economically and socially marginalized members of the community in Sylhet.

Primarily, the organization specialized in youth training projects in order to develop young people's skills and thereby their economic prospects. Since then, SJA has expanded into a respected and innovative organization, covering up to 1.03 million people in the Sylhet & Chittagong division. The organization now focuses its efforts on combating diseases like STI and HIV/ AIDS, malnutrition, social wounds like poverty, illiteracy, unemployment and issues like disability, health and family planning, environment and climate change, water resource management, water and sanitation, good governance, gender sensitization and stop violence against women and children.

SJA is legally registered with the following Ministries and Directorate of Government of Bangladesh:

| Registering Authority | Registration Number & Date |
|------------------------------------|----------------------------------------|
| Dept. of Social Welfare | Syl-284/92, dated 26/10/1992 |
| NGO Affairs Bureau | 860, dated 8/10/1994 |
| Joint Stock Company | S-2826 (339)/02, dated 29/06/ 2002 |
| Dept. of Family Planning | 76/95, dated 06/12/1995 |
| Taxpayer's Identification No (TIN) | 816549106460 |
| VAT | 76/95, dated 06/12/1995 |
| PADOR and SAM Registration | |
| PADOR | EuropeAid ID No-BD-2009-ETW-1008674613 |
| System for Award Management (SAM) | DUNS NUMBER- 731573486 |

SJA's philosophy has always been to empower the most disadvantaged in the community through equipping them with the skills, resources and confidence to improve their own quality of life. Full participation from the community is a core feature of SJA's projects and the organization's success may be largely attributed to its flexibility in responding to the needs of the people.

Through its work, SJA has always strived to develop its own organizational capacity, particularly in participatory planning, the designing of realistic programs and implementing effective monitoring and quality control initiatives

Geographical Presence



Justice for All (JFA) Moulvibazar



Support for legal literacy will increase the awareness of citizens of their rights and their capacity to make meaningful choices to access and utilize legal aid services and formal justice institutions.



The project title called Justice for All (JFA) – Moulvibazar funded by the U.S. Agency for International Development (USAID). Sylhet Jubo Academy (SJA) is implementing Justice for All-Moulvibazar as a local partner of JFA program in Moulvibazar district.

USAID's Justice for All Program takes an integrated approach to improve access to justice for all, combining the empowerment of citizens and justice sector actors with the establishment of strategic partnerships between government organizations and non-governmental organizations to strengthen the systems for legal aid, improve the quality and efficiency of justice services, and increase the availability of information to citizens..

Project Activities

Youth Mobilization (Essay writing and Debate competition)

As a part of youth mobilization initiatives JFA-Moulvibazar has organized 7 essay writing and 7 debate competition in different Upazila of Moulvibazar. Essay writing was organized in high schools' level and debate competition was organized in college level. With the consent of UNO and Upazila Chairman, schools and colleges were selected. Jury board for debate was also decided with recommendation of UNO. Essay competition was held between 15 students in a school who were selected earlier by school authority. Debate was held between 2 teams bearing 3 members each. The subject for both competitions was "Women's barriers to access legal service".



Essay writing at Kulaura Upazila



Debate competition at Rajnagor Upazila.

Leaflet on Govt. Legal Aid Services

In the project period JFA Moulvibazar printed leaflets on govt. legal aid highlighting the services and its benefits. This material was distributed during the project period in events like courtyard meeting, street drama, video projection, folk song, school workshop, miking and other events. This leaflet focused on i) who are allegeable for govt. legal aid fund ii) how they obtain this service iii) who can help them for obtain this service and **iv)** basic rights of citizen of Bangladesh. It will be helpful for mass people for understand the program to get the benefit & services of govt. legal services.

Poster on Basic rights & Legal Aid Services:

The project printed posters focusing the facilities of govt. legal aid services and its benefit. This material was displayed in public hearing, distributed while campaigning, in fair since the targeted audience could get the right message on it. Poster was also used as a visual material to disseminate information at rural level. It contains hotline number of DLA Office (01941-628037), location to DLAC, where to contact and other information.



Bill Board a poster on Govt. Legal Services at UP & Upazila Level:

To create mass awareness and visibility of govt. legal aid the project installed 09 billboards at the upazila headquarters, judge court yard, in front of district jail & other busy places. The boards contain information on the Facilities and services of DLAC. These boards are expected to make people knowledgeable about the basic services of DLAC & office location. District Administration, Upazila Administration, and DLAC extended their support in the installation process.



Installation of Billboard Judge Court, Moulvibazar

Campaign/ Miking of Govt. Legal Aid Services at Upazila level:

The main objective of the activity was to disseminate the information of govt. Legal Aid Services of LACs among the greater community at the working area of the project. Through campaign & miking village people of those particular areas were aware about benefit & services of govt. legal services.

During the project period, the project made total 133 campaigns/ miking at district, Upazila and Union level. Poster, leaflet, information card and radio program cards were distributed to community people.



*Miking & Campaign
Monsornagar Union, Rajnagar Upazilla*



*Miking & Campaign
Najirabad Union, Sadar Upazilla*

Courtyard meetings with member of household Legal Aid Services at UP level:

Courtyard meetings were conducted at the Union level where housewives were given information about Govt. legal aid services and their legal rights. Women were the main target beneficiaries of this program. Each meeting consisted of around 20 persons. The participants were informed about- i) why govt. legal aid fund created for the poor ii) who are eligible for govt. legal aid fund iii) how they obtain this service from LACs and iv) who can help them for obtain this service. The household members actively participated in the meetings. They asked question and sought advice to avail the service from DLAC. IEC materials were distributed among the participants.

National Legal Aid Day Observation:

In the years of 2016, 2017 & 2018 JFA Moulvibazar project observed National Legal Aid Day on 28th April at Upazila and District level arranging extensive programs. The main objective of the day observation is to disseminate the services of LACs among the greater community with in the proposed working area.

To observe the day, the project participated in the symbolic rally, arranged signature campaign, Art competition, contributed to discussion meeting, launched Miking Campaigns, added horse cart in the rally and at the auditorium of Shilpakala Academy of Moulvibazar arranged cultural programs that covered staging a drama by JFA-Moulvi Annual Report of 2018 | 07 team, presenting a docudrama and finally a mime show on legal aid service. At Upazila level the project arranged rally, discussion meeting and conducted miking/ campaign.



Rally on NLAD, Moulvibazar District



Rally on NLAD 2017 Juri Upazila, Moulvibazar.

International Women’s Day 8th March, 2018 Observation:

JFA-Moulvibazar project observed the International Women’s Day in 2017 & 2018. Moulvibazar district administration & District Women’s Affairs office jointly organized the district level events. JFA-Moulvibazar jointly celebrated the daylong program with the district administration.

On 8th March 2018 a discussion meeting which started at 10:30 AM in front of DC Officer. Honorable Member of Parliament, Ex Member of Parliament, Deputy Commissioner, Civil Surgeon, DD (LGED), District Women Affair Officer, District Child Affairs Officer, Chairman of National Women Organization, Journalists, Teachers, Students, Different NGO employee and few other honorable guests were present on the stage. JFA Moulvibazar arranged art competition where Ms. Shahery Mohshin, Member of Parliament, Moulavibazar-03 was present as Chief Guest and panel lawyer of DLAC conducted the event.

Through a collaborative partnership with Bangladeshi institutions and civil society organizations, USAID's Justice for All Program will result in critical gains in access to justice, enabling citizens to exercise and enforce their rights before formal justice institutions. The performance period of the project is from November 16, 2015 to July 31, 2018.



Comprehensive Prevention Program for Female Sex Workers and their Clients

Sylhet Jubo Academy (SJA) is a leading organization along with 22years' experience in working with HIV and AIDS and SRHR services, nutrition and population issues targeting disadvantage population. Since Sex workers are 13 times more vulnerable for HIV compared with general population SJA provides Comprehensive prevention program for these key population. Due to an increased likelihood of being economically and socially vulnerable, unable to negotiate condom use, experiencing violence, criminalization and marginalization female sex workers intervention is very urgently needed in high risk districts such of Dhaka, Sylhet and Chittagong Division. Sex workers faces harassment, violence from the member of law enforcement agencies, muscles men, pimps, madam's other member of our society as well. Beside they always get stigmatized from the society, service providers and even from their own community members.



“Comprehensive Prevention Program for Female Sex Workers and their Clients”:

SJA has currently awarded the GF-FR-Female Sex Worker package for 36 months starting from December 1, 2017 to November 2020 with Light House Consortium (LH, SJA, NMS) under PR Save the Children. During this reporting year SJA provide Comprehensive services for Female Sex Workers and their Clients through managing a total number of 10 Drop-In-Center (DIC) targeting 5000 FSWs of 05 Prioritized district which are vulnerable for HIV epidemic. SJA was contributing to the GOB to achieve universal access to HIV treatment, care and support for those in need.

Drop-in Centers” for Female Sex Workers (FSWs):

The Drop-in Centre is a place where Female sex workers can come to feel safe, exchange information, receive information and counseling about HIV/AIDS, get referrals for testing, get condoms, get information through sessions about HIV/AIDS, get Clinical services Sexually Transmitted Infections (STIs), TB and general women’s health.



All of these DICs had include (a) One Clinic Room along with running water facility (mobile or fixed), enough ventilation and audio-visual privacy (b) 1 room for management

office where DIC Coordinator set (c) one room for Outreach workers (d) One room/space for Store. (e) One rest and recreation room with attest bath for female sex workers.

These DICs followed DIC service guideline which was developed by ASP, Health department of Bangladesh. All Necessary Information are placed in these DICs. The list of SJA managed DICs are given below:

| | | | | |
|--------------------|---------------------|-------------------|---------------------|-------------------|
| Teknaf FSW DIC | Cox's Bazar FSW DIC | Potenga FSW DIC | MohammadpurFS W DIC | KeraniganjFSW DIC |
| Halishahar FSW DIC | Amborkhana FSW DIC | Kodomtali FSW DIC | Narayanganj FSW DIC | DhulaiperFSW DIC |

DIC Services:

- STI management; including treatment & referral
- HIV Testing Services (HTS)
- Rest, bath, recreation, games etc. facilities.
- Peer training
- Provide income generation activities (IGA) training as alternative livelihood
- Group education session at DIC
- Referral services for MCH, FP & EPI and complicated STI.

2. Outreach Services:

- Health education/BCC communication (One to one/group)
- Condom promotion and distribution
- One to one education session
- IEC/BCC activities and distribution
- Satellite Session (STI /HIV Testing & Counseling).

Periodic social mapping and spot analysis by the engagement of community group:

Periodic size estimation and mapping of the FSWs has added with the scope of work aiming to identify the spots and sub-spots wise FSWs and maximizes their accessibility to HIV prevention services. The periodic social and contact mapping 10 DICs as part of updating the mother list. Beside the Community Organizer, a total of 60 community group members were also involved in the social and contact mapping.

Develop Master List and Mother List:

All of Sex workers from the working are particularly highest vulnerable to contracting and transmitting HIV and frequently lack adequate access to services. The project team develop Master list where all of the female sex workers are listed with ID number and information such as name, age, settings, sex frequency, SJA also was developed a mother list which to be updated in each reporting period by following the guideline. In these mother lists Includes/excludes all the sex workers who found in the previous three months. The mother list of sex workers was uploaded to CIS.

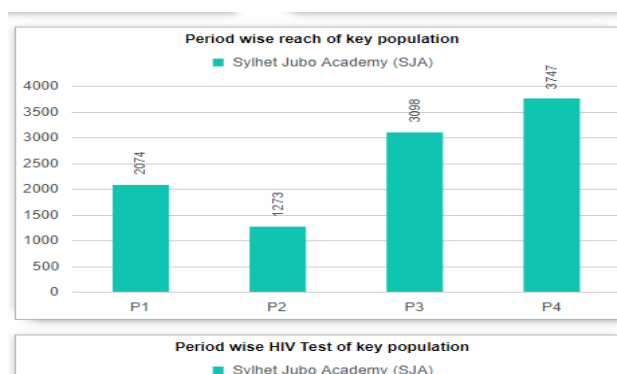

Categories of sex workers:

SJA was covered three **categories** venue-based female sex workers which are Street based FSWs, Hotel based FSWs and residence based FSWs. Street or other public place sex work was the most widespread type of high-risk behavior. Children of sex workers face a number of issues, including early sexual debut, marginalization, separation from parents, and low education levels. More specifically, they are particularly vulnerable to contracting HIV because they are raised in environments characterized by poverty, violence, gender inequality and limited resources that impact their ability to negotiate for safer sex. SJA initiates different activities for adult and adolescent sex workers. Sexual behavior is often initiated in adolescence and is associated with high risks of HIV, sexually transmitted Infections (STI), and unplanned pregnancies.

Clinical Services:

Provide STI management services for FSW and their partners:

FSW are often considered to be at a higher risk for STI. Sexually transmitted diseases (STDs) can be painful, irritating, unbearable, and life threatening. SJA provided STI management services for FSW through its Six DIC Partner notification is an essential part of case management for sexually transmitted infections. Throughout the reporting year, a total of 2657 FSWs and 358 partners of FSWs treated with medication in drop-in-center set up. STI follow up and treatment adherence was also ensured by the DICs.

Management of STI cases through voucher scheme

There are some fields/spots the project has which are far from the DICs; and on the other hand; sex trade investors like hotel management and residence madams doesn't allows FSWs to come to the DICs for having services because, they feel travel times takes a lot, which hampers incomes, movement of FSWs from the hotels and residents makes the LEAs and local community suspicious about running sex trade which ultimately hamper their business. Taking all these facts into consideration, FSW Intervention has initiates the voucher scheme mechanism. In 2018, a total of 197 STI cases were managed through voucher scheme. Achievement took place based on actual case.

Provide HIV Testing Service (HTS): HIV Testing Service (HTS) is available at all of Drop-inCenters (DICs) *locations with testing and counselling*. HIV testing and counseling (HTC) is an essential component for HIV prevention. In 2018 SJA was provided HTS services to 2781 FSW and a total number of 298 sex workers partners.

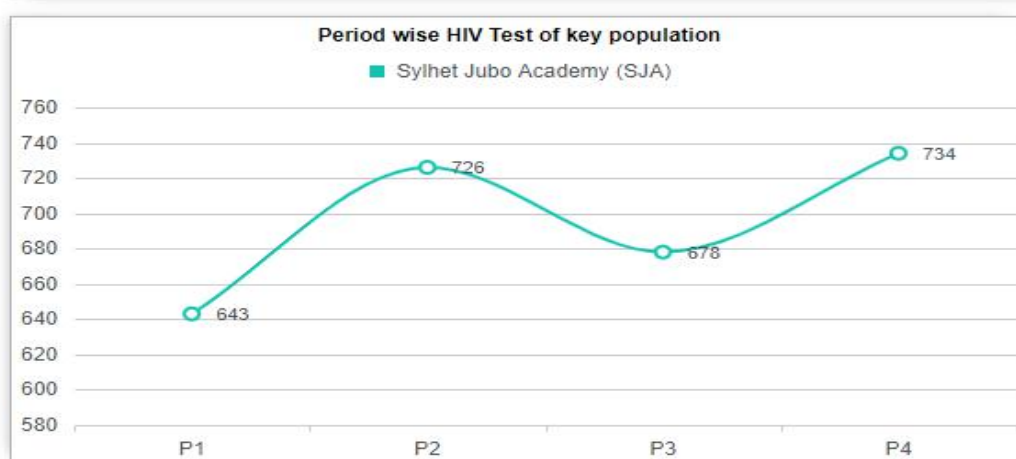

Provide health screening services to FSW:

The DIC clinical team will ensure annual screening for STI, HIV, and others. (i) early detection and management of diseases or medical conditions (ii) raising awareness on risk factors for diseases and (iii) tracking health conditions through medical record. The outreach team is continuously doing the promotional works in favor of health screening through outreach.

Referral of FSWs for maternal health care (MCH)/Reproductive Health

All the DICs have been addressing the unmet needs of the FSWs in collaboration with GO/NGOs. DICs are working together to address the unmet needs like MCH, EPI, TB, GBV, FP, IGA, etc. through developing non-funded MOU.

Part of ensuring MCH services, team has linked a total of 21 FSWs with the local MCH services providers

Referral services for EPI (Expanded Program of Immunization) for children of FSW

As part of safe maternal and child care, collaborative referral services on EPI have integrated with the project activities. All the DICs have developed referral linkage with the local EPI service providers for ensuring the service to the children of FSWs. Throughout the year of 2018, SJA ensured EPI service to the 31 under 1-year children of the FSWs,

Satellite Camp for HIV testing, STI, General Health:

SJA introduced satellite sessions as strategy to create opportunities for HIV Testing & STI services for those who are stigmatized from the society, service providers and even from their own community members remains in distance and are not willing to come to the DICs. These satellite sessions are also applicable for those FSWs as well as who faces obstacles from the residence madams/hotel managers to go outside for having services. During this reporting, a total of 90 satellite sessions were conducted by the DIC team in cooperation of the CBO/SHGs where applicable. The project targeted all individuals sex worker between the ages of 13 and 64 years and their partners be HIV tested in reporting year.

Alternative Income generating activities for FSWs:

Economic empowerment decreases when sex workers get aged or who are willing to change. The old age makes the sex worker's life difficult where no clients, no works and not even they are able to manage their daily food as well. Considering this situation, the project planned to Economic strengthening for female sex workers. Increase their self-esteem and create alternative livelihood through IGA training. In order to Access alternative income generating activities for commercial sex workers, the IGA activities include vocational training and supporting the FSWs who were willing to do something right after having the training. The DIC team was arranged training to FSWs who are willing to change on Income Generating Business. IGA activities through developing MoU through informal collaboration with the local vocational training centers. In 2018, a total of 20 FSWs received skill building training. The major training trades were dry fish processing, beautification, tailoring and block/boutique.



Community group formation:

SJA develop and spread partnership with the community leaders who are trusted by the community and who have commitment and dedication towards the sex worker community for addressing their GBV and human rights. SJA was strengthening community engagement which was very important. SJA implemented Female Sex Worker Intervention, introduced and formed community groups comprised of 5 members each in its each DIC. In 2018 SJA was formatted 10 number of Community group. The Intervention expects that the community group will play major roles in 2 following perspective;

- **Community perspective:** Addressing gender-based violence, minimizing the community conflicts, reduces true violation of human rights from any parties.
- **Project perspective:** Support the DIC team for smooth implementation through minimizing conflicts, addressing GBV as well as providing an update on outreach service delivery scenario to the DICC's through paying planned monitoring visit and social/contact mapping.

SJA was provided Orientation for Community Group (CG) and Conducted Periodic Community Group (CG) meeting.

Community level sensitization meeting with relevant stakeholders for service collaboration and FSW Issue including rights:

The Community level sensitization meeting with the relevant stakeholders aims to create positive environment at cruising level for ensuring service collaboration and FSWs issues including rights. The local musclemen, police, elites, small pretty traders, etc. of the cruising spots were targeted for this sensitization meeting. Throughout the reporting year, SJA organized a total of 21 community level sensitization meeting inside its working areas where participated 88 from different community for a who have influence in the community to support project activities.



Collaboration meeting with GoB health service facilities/referral centers/ local service providers

Referral system plays an important role in health service systems. Strong linkages between community and health facility services encourage clients to seek care and support and help them gain access to services. Additionally, they can help providers track the services that clients receive and then follow up on their healthcare needs.



SJA has been working to strengthen the referral service systems to address the unmet needs from the DICs through formal and informal meetings. As part of this strengthening initiative; a total of 28 formal collaboration meeting with the GO/NGO health service providers were organized during reporting year where 71 participated.

World AIDS Day Observation 2018:

In collaboration with District Civil Surgeon office, SJA observed World AIDS Day 2018. The major events include participating colorful rally and discussion meeting. Beside SJA decorated stall in the WAD exhibitions where consortium partners displayed different project and organizational materials. Beside SJA printed and distributed T-shirts with the moto of WAD and information. All DICs which are situated outside of divisional city also observed World AIDS Day-2018 in collaboration with the district and sub-district (Upazila) administration. The activities include participating the rally, discussion session at CS office, DIC based discussion session with the community members.



DIC level: The major activities of the DICs were designed and implemented under a guiding paper which developed and circulated. The activity details include colorful rally; discussion session; information booth in an important place of the city of Chittagong, Cox's Bazar and Sylhet; wish tree to express needs of services; quiz competition; signature campaign in favor of GBV; and 7 days long HTS campaign program, etc.



International Women Day Observation 2018:

In collaboration with the Department of Women Affairs and Light House Consortium, SJA observed International Women Day 2018 during 1st quarter of the reporting year. Part of this, a human chain organized by Department of Women & Children Affairs on March 6th which was supported by SJA. The DICs observed the day in collaboration with the division, district and sub-district level GOB administration. A total of 300 representatives from the sex workers community and their leaders, DIC team, etc. participated the rally and human chain organized by local administration. Besides, the DICs conducted several discussion sessions related to gender-based violence where 270 FSWs participated.



The activities planned to observe the International Women Day 2018 jointly with Sex Worker's Network in collaboration with Women and Children Affairs of Bangladesh Government and relevant district and sub-district level authorities as well as NGOs working for the same. The DICs were arranged social mobilization campaign where discussion session on the importance of women empowerment and GBV, etc. DIC organized rally/seminar/human chain as organized by the local administration.

Provide peer outreach education to FSW:

The outreach services for FSW Intervention are severely depends on the spot characteristics and sex trade dynamics e.g. availability of FSWs, availability of clients, vigilance activities by law enforcement agency, characteristics of stakeholders, political situation, etc. Community Organizer is one of that position who are recruited from the community to play the key roles for changing behavior and attitude among the targeted population at grass root level through providing outreach peer education on selected eight topics equally distributed (three per month) for each reporting period.

Conduct group education session at DIC with FSWs

The Field Monitors or skilled Community Organizers usually perform group education sessions at DIC level. Similar to outreach, here also discussed 8 topics as part of behavior change communication. Throughout the reporting year, total 2401 beneficiaries participated in 454 group sessions and the overall achievement stands on 137% comparing to the target. Light House has initiated a trail program in P4 (October to December 2018) to see the feasibility of arranging daily group health education session at DIC level which cause over achievement.



Orientation session on Legal Aid, GBV and Human Rights issues for FSWs

The FSW community always faces stigma, discrimination and violence in different forms from the community, LEAs, clients, pimps, madams, and even from their family due their ignorance on rights being human and available legal aid service facilities. The project has planned to build the capacity of the FSWs through providing orientation on laws and legal supports in collaboration with the GO/NGOs who works on human rights and legal supports. The major objective of the event was to provide a clear understanding which will empower the FSWs on their rights related knowledge as well as from where and how they will get the legal aid support.

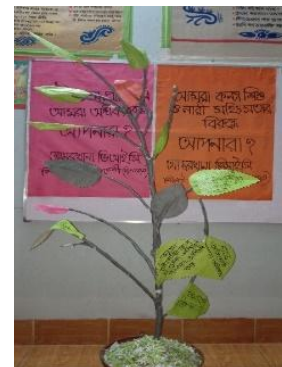

Promoting safer sex: Promoting safer sex through increased condom use, Behavior change communication, peer education, social marketing. There are many ways of distributing and promoting condoms. Condom promotion and its distribution was one of the major elements of the HIV prevention program of SJA. Free distribution and social marketing both work to promote condoms.

Provide male condoms for female sex workers free of cost:

Save the Children International was provided free condoms. Throughout the reporting year, SJA distributed a total of 822996 condoms to female sex workers with free of cost.

Provide male condoms for sex workers through Social Marketing initiative

Though the social marketing project team encourages practices in buying condoms which is good for future sustainability. Social marketing of condoms simultaneously until the KPs takes buying condom as part of their prevention need. However; throughout the reporting year, a total of 3301704 male condoms distributed among the FSWs free of cost against the targeted distribution for the year of 2018.

For creating buying habit among the female sex workers, the project initiated social marketing of condom using the peer outreach worker and peer volunteers, etc. Under the social marketing approach, DICs procured condoms from the single vendor (social marketing of company) and sold it without profit. The project scope work states about 20% condom distribution through free of cost and 80% through SMI.

Provide lubricants for female sex workers free of cost

Using lubrication during sex is important for safer sexual practices. FSW always entertains quite a high number of clients where it seems very normal of less vaginal secretion which causes to dry the area in most cases. Lubrication can moisten those areas, which can allow for proper stretching of the skin and tissue when inserting the penis. Lubrication also allows for there to be less rubbing and friction as the shaft is pushed deeper into the cavity. Lubrication also makes condoms much more effective and less susceptible to ripping and breaking because of the friction. Keeping importance of using lubrication to enhance safer sex and prevent the breaking of condoms, the project has been ensuring accessibility to lubrication gel with free of cost. Throughout this reporting year, a total of 45,533 lubricants (20ml) distributed among the FSWs free of cost.

Case Study:



A 28 years old female sex workers who live in Maikpara, Eidgah upazila under Cox's Bazar district. She was growing up in a happy family along with parents and a sister but suddenly her father got second marriage and stopped providing support to their family. After around three years, her mother suddenly died. Later she was raped by her step brother. In such situation, she was habituated to accept the violence. She said "I was Started for Cox's bazar by a Bus. I did not have any single penny with me that I shared to the Bus contractor to get relief. Listening to me, he got sorrow and

said that he had an aunt in Cox's Bazar who lives alone, if I want than she can arrange my staying. I got agreed and went there, the aunt was a residence madam where the Bus Contractor raped me two days and later, I revealed no option in front except sex profession and that was my starting. For around 7-8 years at a stress I was involved with sex work and I worked on street, residence and started going on call as well. Once I met a staff of Cox's Drop-in-centers and she took me at the drop-in-center and brief about the center's services. I started visiting the center frequently and came to know later about the support of vocational training. Opportunity came once and got IGA training. She told "As I had good amount of deposit from the sex work which helped me in establishing a dry fish selling shop at Borobazar Market, Cox's Bazar. Now I process dry fish my own and sell through my shop which gives me daily around taka 500-600 benefit on average. My business is my life now, my dream now. I am living with dignity, no one says me a sex worker, no one call me to have sex. I am happy, I want to forget the past."



Community Participated Safe Water Project

[Installation of 24 Shallow Water Well]

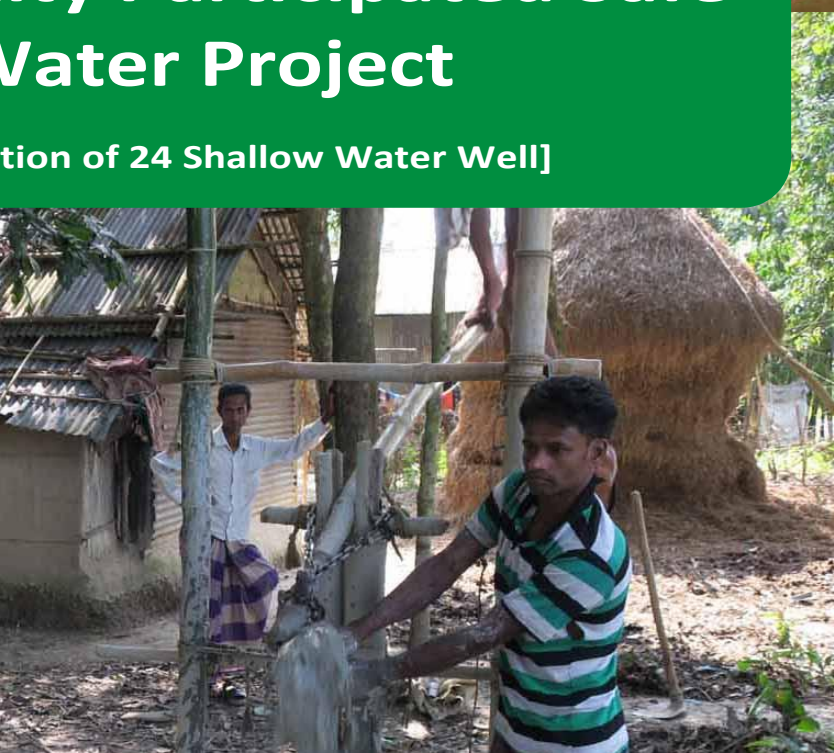

An effective and acceptable to address the community and individual safety, resilience and wellbeing. The project adopted a strong community-based approach. In order to ensure service were provided to previously underserved group of people.



PROJECT OVERVIEW

The project title called Community Participated Safe Water Project 24 Shallow Water-wells funded by Penny Appeal. The project was started in 1st June, 2018 and ended by 30 June, 2018. 24nos of shallow Water-wells installed/ Wells have been set up at rural villages of Rajnagar and Zakigonj Upazila under Moulvibazar and Sylhet district of Bangladesh where 474 people of 103 house-holds have easy access and enjoying the safe water facilities at their doorstep.

SJA deals with people in distress, who are poverty stricken, socio-economically marginalized, illiterate, disable, gender discriminated, creed, ethnicity and so and thereby excluded. Women and children, the most vulnerable group of the population, are the primary concern of SJA. The organization promisingly and persistently works to uplift the downtrodden, and to bring sustainable changes in the life of deprived people.

Bangladesh's population density, low-lying lands and vulnerability to floods, monsoons and cyclone leave the population more exposed to water contamination. The country from its ancient time is famous for its water resources including the surface water and near surface ground water. Before the advent of hand pumps/tube wells the people used to depend on natural surface water of rivers, canal, lakes and man made water reservoirs like ponds and wells. Due to water from that sources caused the spread of cholera, diarrhea, arsenicosis, skin cancer, skin lesions, neurological effects, internal cancers of bladder, kidney and lungs fluorosis, guinea, warm diseases, intestinal worms, malaria, trachoma, typhoid, skin diseases and other virus-related diseases at a very high rate.

The targeted beneficiaries are living below and at the poverty level at hard to reach areas. Lack of basic facilities makes them deprived from all aspects; illiteracy, ignorance of health and hygiene is acute. Due to poverty and ignorance they were drinking unsafe surface water from pond/river and open water that causes for various waterborne diseases. Considering these circumstances SJA were implemented the safe water project at the rural villages of Rajnagar and Zakigonj Upazilas under Moulvibazar and Sylhet districts with the support of Penny Appeal.

SJA carries out the programme by the following process:

- Obtain Government approval from NGO Affairs Bureau.
- Informed about the programme and Penny Appeal to the local level government administration at District and Upazila (Sub-district).
- SJA personals made survey to primarily identify the location where SWW can be installed.
- Community mobilization through group meeting.
- Area/site selection of water point and finalization.
- Community fund mobilization as part of cost share.
- Selection of Skilled Mason for boring/installation of water points.
- STW/HP boring/installation.
- Water testing.
- Platform development.
- Water Points Maintenance (WPM) Committee formation.

The programme Installation site of 24 STWs are:

| Country | Division | District | Upazila | Union | No of Villages |
|--------------|----------|-------------|-----------|-------------|----------------|
| Bangladesh | Sylhet | Moulvibazar | Rajnagar | Munshibazar | 04 |
| | | Sylhet | Zakigonj | Barothakury | 03 |
| | | | | Manikpur | 01 |
| | | | | Kajolsha | 01 |
| Total | | 02 | 02 | 04 | 09 |

Beneficiary Data

Based on the total programme for this period/quarter, here summaries the direct and indirect beneficiary's breakdown by its type:

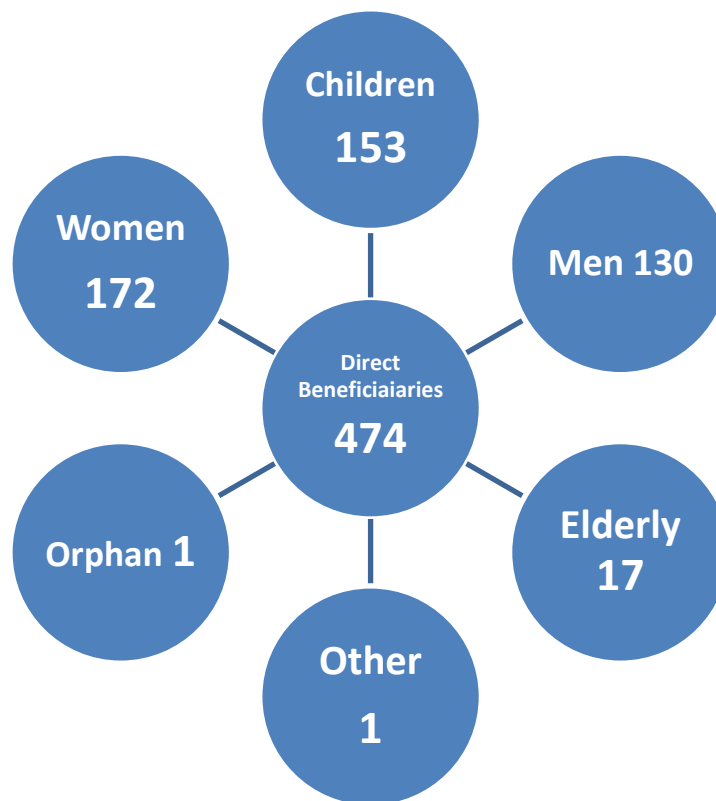

Chart: A chart of the direct beneficiaries.

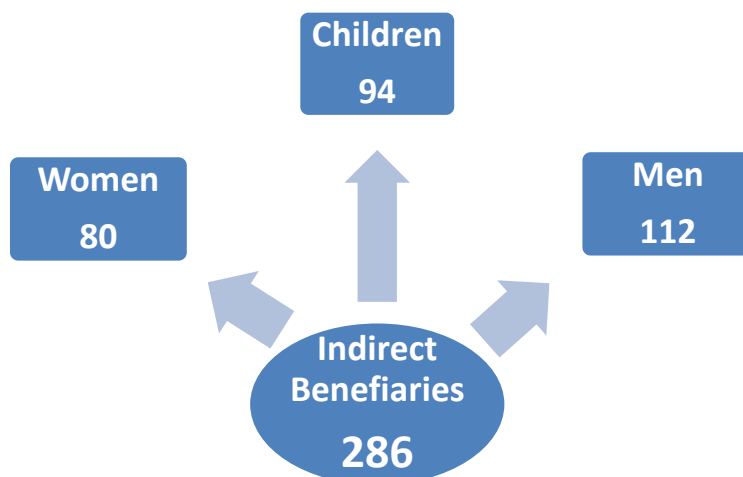

Chart: A chart of the indirect beneficiaries.

All the selected beneficiaries are poor and marginalized and living in the rural areas. Women and girls have easy access of safe drinking water at their doorstep, so they no need to go far to collect safe water that make their lives easier especially for pregnant women and their social dignity ensured thus the women and girls are benefited.

In many cases the water layer depth cross the fixed depth target and need to dig more, so in that cases it's difficult to collect/manage additional expenses from the poor beneficiaries. To collect photographs of different three steps/stages like selection/marketing of water points, boring/installation and after setting of platform and plaque which requires a huge number of manpower and travel to a single site to collect these three stages of picture that is very difficult for us. In addition, for this reason the STW/HPs installation duration takes very long times. This project should include separate allocation for travel cost to travel of hard-to-reach/rural areas because in a single STW/HP location 4-5 times needs to travel to meet/fulfill PA criterion. Finally, natural calamities (flood) and heavy rain hampered to on-time completion of the project activities.

After successful completion of the said project targeted beneficiaries lead healthy life and their living environment are improved. Their unpredicted expenditures of waterborne diseases are reduced and especially their next generation will grow up in a healthy environment.

The project activities monitored and evaluated on regular basis both internally and externally in terms of quality services attainment, target achievement and impact making. For smooth functioning of the project SJA assigned senior and mid-level staffs to make frequent site visit for monitored the works. Instead of this local community people and beneficiaries are also in process of monitoring and evaluation.

Since the beginning potential stakeholders like elected representatives, local elites, teachers, religious leader, youths and the beneficiaries are involved of whole process from starting to end. The targeted beneficiaries came forward with their full efforts and make contribution to developed/set platform of respective Shallow Water Well that creates a positive atmosphere and ownership among them. In addition, for each and every water point a "water point maintenance committee" has been setup along with female member representation for any decision making and regular maintenance of respective water point in future. Thus, the project will sustain itself.

Community Participated Safe Water Project

[Installation of 200nos of Shallow Water Well]

Clean and accessible water for all is an essential part of the world. Our holistic approach builds on local resources and relationships to nurture such an environment. Its design and implementation provide lessons for the water projects involving poor communities and ethnic minorities as the core beneficiaries.



Bangladesh's population density, low-lying lands and vulnerability to floods, monsoons and cyclone leave the population more exposed to water contamination. The country from its ancient time is famous for its water resources including the surface water and near surface ground water. Before the advent of hand pumps/tube wells the people used to depend on natural surface water of rivers, canal, lakes and man made water reservoirs like ponds and wells. Due to water from that sources caused the spread of cholera, diarrhea, arsenicosis, skin cancer, skin lesions, neurological effects, internal cancers of bladder, kidney and lungs fluorosis, guinea, worm diseases, intestinal worms, malaria, trachoma, typhoid, skin diseases and other virus related diseases at a very high rate.

The targeted beneficiaries are living below and at the poverty level at hard to reach areas. Lack of basic facilities makes them deprived from all aspects; illiteracy, ignorance of health and hygiene is acute. Due to poverty and ignorance they were drinking unsafe surface water from pond/river and open water that causes for various waterborne diseases. Considering these circumstances SJA were implemented the safe water project at the rural villages of Rajnagar and South Surma Upazilas under Moulvibazar and Sylhet districts with the support of Penny Appeal.

The programme delivered/Installation site of 150 STWs are:

| Country | Division | District | Upazila | Union | No of Villages |
|--------------|----------|-------------|-------------|-------------|----------------|
| Bangladesh | Sylhet | Moulvibazar | Rajnagar | Munshibazar | 17 |
| | | Sylhet | South Surma | Jalalpur | 09 |
| | | | | Moglabazar | 02 |
| | | | | Shilam | 09 |
| Total | | 02 | 02 | 04 | 37 |

Under this project the hard-to-reach and disserted people were benefited like orphans, elderly, disablespecially pregnant women, mothers and children.

The beneficiaries were selected through a participatory process by active participation and involvement of community people, local elected representatives, local elites and local government administration along with SJA staff members.

The project beneficiaries participated in decision making from the beginning stage to during implementation and monitoring of quality works; like selection of beneficiary households, selection of land where SWW/HP installed, sharing of their opinion on materials, collection of their own contribution to build platform as cost share and formation of water point maintenance committee etc.



Beneficiary Data

Based on the total programme for this period here summerises the direct and indirect beneficiary's breakdown by its type:

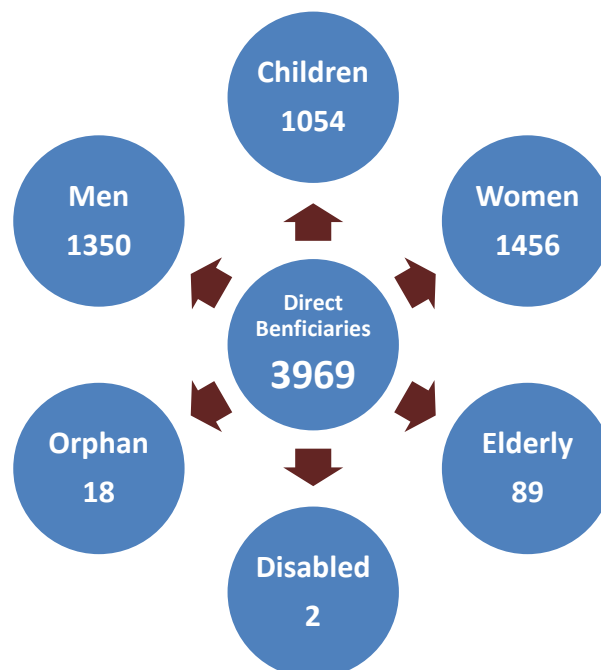

Chart: A chart of the direct beneficiaries.

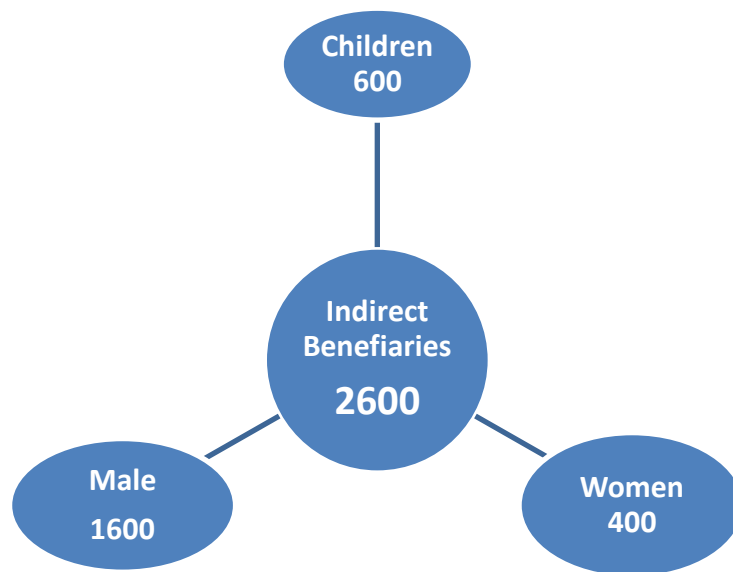

Chart: A chart of the indirect beneficiaries.

The targeted beneficiaries of the 200 SWWs are marginalized among these three households have disable person.

Women and girls have easy access of safe drinking water at their doorstep, so they no need to go far to collect safe water that make their lives easier especially for pregnant women and their social dignity ensured thus the women and girls are benefited.

Project Issues, Lessons Learnt & Impact

- In many cases the water layer depth cross the fixed depth target and need to dig more, so in that cases it's difficult to collect/manage additional expenses from the poor beneficiaries.
- To collect photographs of different three steps/stages like selection/marketing of water points, boring/installation and after setting of platform and plaque which requires a huge number of manpower and travel to a single site to collect these three stages of picture that is very difficult for us. In addition, for this reason the STW/HPs installation duration takes very long times.
- This project should include separate allocation for travel cost to travel of hard-to-reach/rural areas because in a single STW/HP location 4-5 times needs to travel to meet/fulfill PA criterion.
- Finally, natural calamities (flood) and heavy rain hampered to on-time completion of the project activities.

After successful completion of the said project targeted beneficiaries lead healthy life and their living environment are improved. Their unpredicted expenditures of waterborne

diseases are reduced and especially their next generation will grow up in a healthy environment.

The project activities monitored and evaluated on regular basis both internally and externally in terms of quality services attainment, target achievement and impact making. For smooth functioning of the project SJA assigned senior and mid-level staffs to make frequent site visit for monitored the works. Instead of this local community people and beneficiares are also in process of monitoring and evaluation.

Since the beginning potential stakeholders like elected representatives, local elites, teachers, religious leader, youths and the beneficiaries are involved of whole process from starting to end. The targeted beneficiaries came forward with their full efforts and make contribution to developed/set platform of respective Shallow Water Well that creates a positive atmosphere and ownership among them. In addition, for each and every water point a “water point maintenance committee” has been setup along with female member representation for any decision making and regular maintenance of respective water point in future. Thus, the project will sustain itself.



“Improving health and social well-being of adolescent Female sex workers enhanced access to essential services” MARA Project



A large number of female sex workers are children or adolescent. Working with most-at-risk young people is challenging, especially if they are below the age of 18, being sexually exploited or engaging in illegal behaviors. Any human being below the age of 18 is defined as a child. Some young people may be especially vulnerable to HIV, or just one step away from engaging in high-risk behaviour. Because of legal and other barriers, young people involved in HIV risk behaviours are marginalised and not reached by mainstream HIV prevention and treatment efforts. They may experience stigmatization, discrimination and social exclusion. Although, young people engaging in HIV risk behaviour need many of the same types of HIV prevention treatment, care and support interventions as their older counterparts, they also require programmes tailored to their specific needs, including those related to age and psychosocial development. Considering above factors, SJA run Improving health and social well-being of adolescent Female sex workers enhanced access to essential services” Project for Most at Risk Adolescent (MARA). This project Funded by- UNICEF, supported by- Save the children.

Project GOALS & OBJECTIVE:

Goal: Reduce HIV/AIDS and STD Infection and decrease stigma, GBV and discrimination.

Objective:

- Increase coverage and deliver customized services for adolescent FSW
- To facilitate engagement of adolescent FSW through participation and networking.
- Conduct Advocacy with stakeholder.
- Generate evidence for adolescent FSW intervention and process documentation.

Activities at a Glance:

The project activities were designed and implemented to achieve the four objectives which include (i) Increase coverage and deliver customized services for Adolescent FSWs (ii) Facilitate engagement of adolescent FSWs through participation and networking (iii) Conduct Advocacy with stakeholders (iv) Generate evidences for Adolescent FSW intervention and Process Documentation.



SJA is implementing MARA project by four FSW DIC. The brief of these DICs are given below:

Project area and coverage:

The project under this sub- grant agreement was implemented in Chattogram and Sylhet City Corporation. The intervention has been reached an estimated 400 adolescent FSWs through global fund supported existing 4 DIC.

| Activities | Achievements |
|--------------------------------------------------------------------------------------------------------------|--------------|
| Identify and enroll adolescent female adolescent sex workers | 357 |
| Conduct Peer education (One to one and Group) focus on Adolescent FSWs issues | 2722 |
| Voucher scheme for referral of STI, HTC etc. at DIC | 120 |
| Facilitate Birth registration services and create linkages with authorities | 63 |
| Facilitate formation of Adolescent FSW peer groups | 28 |
| Establish regular communication with Group leaders/ Adolescent Peer Educator | 140 |
| Provide vocational training for alternative livelihood | 20 |
| Facilitate financial inclusion by opening of individual bank account (Conventional/ Mobile Banking Services) | 11 |
| Organize monthly group meeting | 82 |
| Provided Service card | 357 |

Key services for MARA by FSW DICs

- Outreach
- HIV Testing Service
- Condom promotion
- STI management
- General Health Screening
- Referral services for MCH, FP & EPI and complicated STI
- Harassment management
- Reducing stigma and discrimination
- Social reintegration
- Advocacy

- Community empowerment†
- Rest, Recreation and entertainment
- Counseling and good practice sharing

SJA hired a total of 04 Community Mobilizer (Adolescent Program) from the adolescent & youth (15-24 years) age group for each drop-in-center based on the project plan. Each Community Mobilizer was responsible to carry out the group activities targeting 100 AFSWs.

Conduct Peer education (One to one and Group) focus on Adolescent FSWs issues:

Using SCI developed materials, the Community Mobilizers conducted one to one and group education sessions

Disseminate Adolescent FSW focused IEC/BCC materials on GBV, RH, HIV and AIDS

Behavior change communication (BCC) for most-at-risk young people was promoted individual behavior change such as the use of condoms, and reduction in number of sexual partners. BCC should also promote positive behaviors associated with treatment, care and support, including adherence to treatment of sexually transmitted infections (STIs). SCI developed flip chart and leaflets for the project. And provided 2,000 leaflets and 24 set of flip charts to SJA, of which, distributed 1600 pcs of leaflets to the selected five drop-in-centers of the project. Besides 04 flip charts distributed to the all 04 drop-in-centers, supported by The Global Fund including project supported the four drop-in-center in Sylhet and Chittagong Division.

1.4a Voucher scheme for referral of STI, HTC etc. at DIC

For making the adolescent sex workers interested towards having the health care services from FSW DIC (Potenga, Halishahar, Amborkhana, Kodomtali), the project introduced specific voucher schemes. Throughout the project period, out of targeted 400, a total of 381 cases were referred to DICs for HTS, STI and health screening as well.

Facilitate with Birth registration services

Birth registration is a fundamental right of all children, Due to social stigma and lack of awareness, a significant portion of the target group found not have birth registration card. But it was need to prevent early child marriage among adolescent FSWs and also to avoid their early pregnancy. For this, the birth registration for the unregistered AFSWs was initiated by the project. And throughout the project period, a total of 81 adolescents FSWs were brought under birth registration.

Operationalize Partner Project Staff through procuring furniture and equipment

A total of one laptop and 4 TABs were procured throughout the project period by maintaining the project compliance.

Enhanced participation, networking and engagement of adolescent female sex workers through capacity building, social and financial inclusion;

Formation of adolescent FSW peer groups at community level

Adolescent FSWs are more mobile and scattered. Realizing that, reaching them through a conventional way doesn't bring such results. To ensure effective reaching of adolescent FSWs, Community Mobilizers will work for formation of Adolescent FSWs peer group at the community level. It was planned that the group will form with 8-12 adolescent FSWs and a group leader will be selected among them who will work as an Adolescent Peer Educator (APE) within the group. Under this concept, the project formed a total of 40 groups covering 400 AFWs and on an average, each group was comprised with 10 members. The all groups were remained functional until the last day of the project. From the, sustainability point of view, both SCI and SJA agreed to motivate the group members of MARA project to continue further and as possible, create option for engaging the MARA population in different day observation and other events under ongoing FSW Intervention.



Establish regular communication with Group leaders/ Adolescent Peer Educator

For keeping the group leaders and adolescent peer educators on track, increasing their understanding and providing OJT, the project coordinator established regular communication through ensuring physical visit, making open telephonic discussion and allowing meeting as require.

Provide vocational training for alternative livelihood

Our society is still not ready to accept sex work as profession which causes the implementation of sex worker intervention challenging. Beside they always get stigmatized from the society, service providers and even from their own community members. The sex worker's demand remains very high during their teenage and middle age but in the same time their demand decreases while they get aged. The old age makes the sex worker's life difficult where no, clients, no works and not even they are able to manage their daily bread as well.

Considering the above situation, the project planned to increase their self-esteem and create alternative livelihood through IGA training and similarly tried to create enabling environment for them so that they can enjoy their full human rights with dignity. The alternative livelihood activities include vocational training and supporting the FSWs who were willing to do something right after having the training. The Project team arranged vocational training through developing MoU with the renowned five resource person of the locality. Through the out the project period, SJA brought 65 AFSWs under vocational training right after conducting need assessment. The major trade of the vocational training includes tailoring and beatification. A total of 65 AFSWs received training.

Linkage with banking services for financial inclusion.

Financial stability helps anyone to become empowered. The female sex worker project implementation experience as well as a study conducted by the HIV/AIDS program of Save the Children, states that there are very negligible portion of FSWs having bank account and in most cases their incomes are often snatched by the mastan, pimps, babus (regular partner) and their husband. Based on above circumstances; the project realized that to empower sex workers, no alternative, except keeping their income safe.

Part of this SJA was targeted to open bank account for 50% of the targeted beneficiaries but ultimately procedural barriers (like NID for AFSWs or their parents) to open bank account for the adolescent limit the initiative. However; throughout the project period, it was possible to open bank account for 31 AFSWs only.



Khasdobir Education, Welfare and Development Project (KEWDP)



Education, a right and a crucial opportunity and holds the key for increasing resilience and impacting future generations with wide-reaching socio-economic and communal benefits.



Khasdobir Education, Welfare and Development Project (KEWDP) were designed in aiming to continuing the previous services to the selected beneficiaries without any programmatic interruption. Basically, in previous the similar nature of project was implemented by a local organization namely KYAG since long with the support of Friends of Khasdobir-UK and from 30 June 2018 KYAG funding support was suspended by the Friends of Khasdobir-UK and through proper organizational appraisal this project is switch/handed over to the Sylhet Jubo Academy (SJA). As per project planning and donor desires it was determined that KYAG handed over the entire project components along with their existing human resources to SJA but it was very unfortunate that the non-cooperation and resistive attitude of KYAG effect drawback to commence the targeted project intervention. At least more than three months (from May to July'18) period SJA senior management and the respective Project Manager of KEWDP paid continuous communication with KYAG and tried best to get positive cooperation from KYAG for smooth operation of the said project but KYAG nakedly shown their unprofessional attitude. However, considering all the realities and circumstances SJA already decided to continuing project functioning without any further delay.

PROJECT ACTIVITIES

The project arranged a 3 days long basic training for its teachers on preprimary education teaching technique where the project program monitoring officer also participated along with the Teacher in charge & Assistant teachers of 8 centers. The training was conducted by Assistant Upazila Education Officer from government primary education department, who has vast of knowledge and expertise on early childhood development as well preprimary education. After completion of successful training session, a formal closing ceremony was hold at project office where Assistant District Primary Education Officer (ADPEO) was present as Chief Guest and Upazila Education Officer (UEO) as special guest. The visiting guests express their satisfaction on KEWDP activities and assure the required cooperation from their side in future program intervention. The session presided by A H M Faisal Ahmed, Executive Director of SJA, and Mr. Michael John Sherriff, Chairman of Friends of Khasdobir-UK was present as guest of honor. All the successful participants were provided certificates.



Vocational Sewing Training for Young Women

Through conduction of door to door survey SJA selected and enrolled 40 nos. of unprivileged unemployed young women from the locality for Vocational / Sewing training.

From September, 2018 the sewing training was started and the 40 trainees are providing skill/lessons through two batches. In each batch 20 trainees.

Each batch are providing 3 days classes for minimum of two hours daily and two batches are providing training on every alternate day.

The training module contains sixteen (16) items of ladies and kids dress making (Cutting & Sewing) where including latest design of dresses.

It is here to be noted that, by this period out of 40 trainees 4 trainees already engaged in income generation by collection of working order from outside.



Computer Training for Underprivileged Students

Computer training is an important factor in 21st century. It is a fact that computer literacy is a crucial skill that is required in every sector of life from studies to the job market. A large percentage of people in Bangladesh are underprivileged and unemployed. But IT sector is a great area for developing their economic status. Mostly freelancing and outsourcing is an excellent opportunity for the young and unemployed peoples. After learning some computer skills these underprivileged peoples can develop their economic status by working in the online market as well as in the local market.

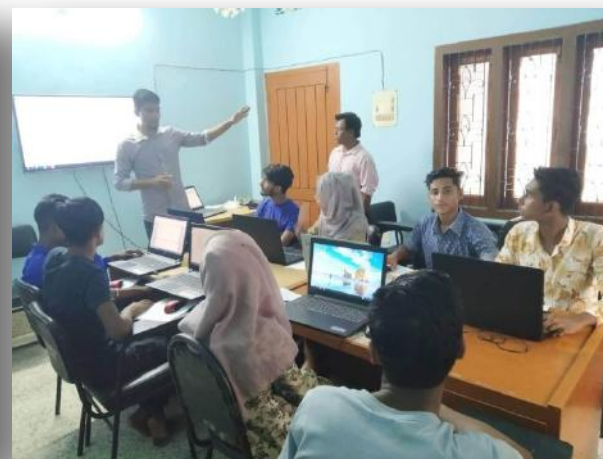

Distribution of Widows Allowances

- To select appropriate person who has actual rights and need to get allowances from the project there were participatory involvement process has been ensured. The local Counselor (elected representatives) of Sylhet City Corporation, elites, teachers and SJA team jointly selected the beneficiaries where the previous listed widows got priorities. Under this project a total of 70 widows have been selected for the first year of project period.
- Widows allowances providing on monthly basis and started from September'2018. The beneficiaries are providing their allowances on the first week of subsequent/following month. During this 1st half of project period 3 times widows' allowance has been distributed (from September to November, 2018). To ensure the transparent distribution process guests are inviting from outside to attend the distribution ceremony events and provide the allowance by themselves; where from the government administration Upazila Nirbahi Officer (UNO) from Sylhet Sadar, Counselor (elected representatives) of Sylhet City Corporation (SCC) were present. Also, in second month's distribution the honorable trustees of Friends of Khasdobir-UK, Ms. Sue and Ms. Maureen were present and handed over the allowance to the widows.
- By receiving of signature/Thumb press acknowledgement of widows 'allowance are providing.



Photo: Widows allowances distribution ceremony.

Job Training

SJA arranged day long On the Job training for the project staff. The training conducted the honorable Executive director of SJA Mr. A H M Faisal Ahmed. Through this training the staffs gather knowledge about SJA's Rules and regulation. The honorable Chairperson of Friends of Khasdobir-UK, Mr. Mike Sherriff also had presented this training.

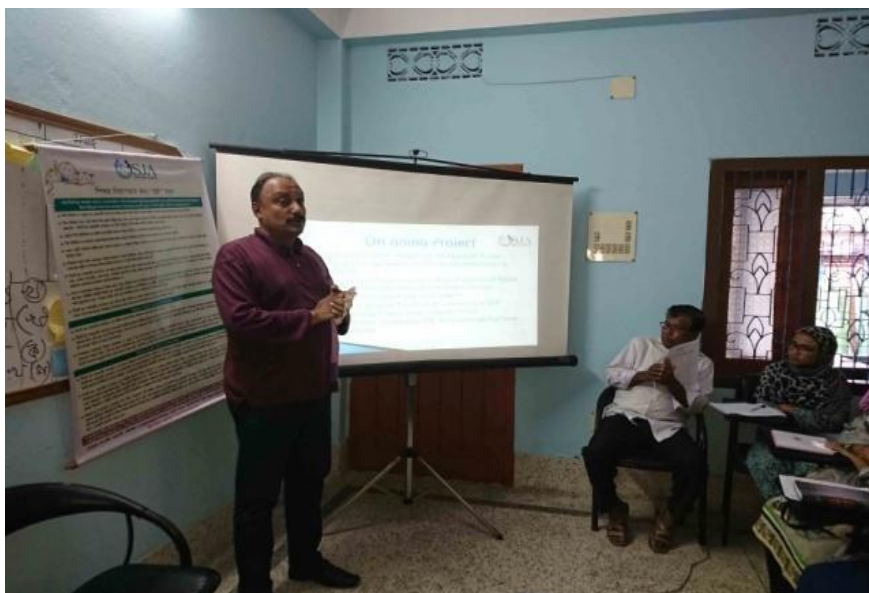

SJA's Contribution to this project

For setup of project office and office premises education centre SJA management is kind enough to made kind contribution to the project by providing of required number of necessary office furniture, electric equipment, computer with printer, carpet for the class, training room furniture and cookeries etc. That is approximately value of BDT-315,000.

For any kind of successful project implementation commitment of higher management of the respective organizations is important. Nothing is impossible if we are committed and dedicated to the service. If any negative circumstances arise joint effort of teamwork is the main strength to overcome the situation and to attain the targeted goal. Proper way of communication and respect to each other especially the community people facilitate to engage the primary and secondary stakeholder with participatory implementing process.

The children are from poor families of slum areas and coming to the classes at morning. So, mostly the children don't have time to get breakfast at their home before coming to the preprimary education centre. After an hour of classes, they felt hungry and start crying, in this situation the respective teachers facing difficulties to manage them and conduct the sessions.

Community Participated Safe Water Project

[Installation of 700 Shallow Water Well]



Project Overview

The project title is Community Participated Safe Water Project (700 STW), funded by Penny Appeal UK. SJA has been implementing 12 months duration (July'18 – June'19) project in the five (5) Upazilas of Moulvibazar and Sylhet districts under Sylhet division of Bangladesh. During this reporting period a total of 508 SWT have been fully installed and functioning in 4 Upazilas. There are total 12372 people directly and 49788 people indirectly benefitted by this project. Also, 2492 house-holds covered through this project

Access to safe water and sanitation are basic determinants of better health. Limited access to safe drinking water and sanitation facilities and poor hygiene are associated with skin diseases, acute respiratory infections (ARIs), and diarrheal diseases, the leading preventable diseases in Bangladesh. ARI remains the leading cause of child deaths in Bangladesh. Diarrheal deaths and prevalence of diarrheal diseases among children under age 5 have declined. Bangladesh's population density, low-lying lands and vulnerability to floods, monsoons and cyclone leave the population more exposed to water contamination. The country from its ancient time is famous for its water resources including the surface water and near surface ground water. Before the advent of hand pumps/tube wells the people used to depend on natural surface water of rivers, canal, lakes and man made water reservoirs like ponds and wells.

The project's targeted beneficiaries are living below and at the poverty line. Lack of basic facilities makes them deprived from all aspects; illiteracy, ignorance of health and hygiene is acute. Due to poverty and ignorance they are drinking unsafe surface water from pond/river and open water that causes for various waterborne diseases.

Project Objective

During this reporting period the project achieved the following:

- Ensure access to safe water supply options, use and maintain by 2492 HH of project area.
- 12372 people of 2492 HHs have access to safe water facilities.
- 2492 household's hygiene behaviors are increasing.
- Among the community waterborne related morbidity rate will be reduced.

Project Location

| Country | Division/ Province | District | Upazila | Number of Union | Number of Village |
|------------|-----------------------|-------------|----------------------------------------------------|--------------------|----------------------|
| Bangladesh | Sylhet | Moulvibazar | Rajnagar | 06 | 71 |
| | | Sylhet | Fenchuganj, South Surma, Sylhet Sadar and Zakigonj | 16 | 136 |

As a part of monitoring the project team made regular visit in respective field to monitor the installation of STWs and to take required photographs. During field level monitoring sometimes local elites and local government representatives were invited with the project team to oversee the progress of installation and as well the materials. In this process the team will discuss with the respective beneficiary families to get their views and suggestion if they have; which also consider the satisfaction level of beneficiaries. At the STW installation period some time arguments arise among the beneficiaries for digging site selection and that time on the spot it was minimized with the presence of local elected representatives and influential person of the locality.

From SJA management the Executive Director made by-monthly monitoring visit to the field; where he and management team looks in the selection of beneficiaries, digging of STWs and discussed with the community people and mason as well. On the other hand, the management team spot check as sampling basis, check the water supply, discussed with the respective HH's about to cleanliness and maintenance of STW and about the donor who provide grant for installation of STW. SJA invites upazila administration to monitor the program and UNO of Rajnagar Upazila visited the few STWs installation/digging sites, completed sites and discussed with the community.

Case Study

A Case Study on Safe Water

Asma Begum, age 40 years old lives in the Moulvibazar, upazilla Rajnagar, Uttorbhag union, in a village called Uttorbhag Uttor. She is a housewife. Her monthly income is about 4,000 Taka. In her house, there are a couple of poor families with figure of 15 members in whole. This is a huge number for her because she is the one and only earning person in these families.



Water supply is an essential issue of public health. Also, this is the fundamental rights of every human being. Unfortunately, despite best efforts, the country has not been able to tackle the issue effectively. Without clean water, we have seen an onslaught of chronic intestinal infections that have caused stunting amongst children. Children who are stunted fail to grow to full physical structure and mental capabilities. With diarrhea comes the

problem of not being able to attend school regularly. Chronic diarrhea leads to severe malnutrition. These ailments need to be addressed as they come from poor quality drinking water.

On the other hand, in the household of Asma Begum, there is a little pond which is totally affected by dirty as well as unsafe water. Undoubtedly, they use this water daily. Though, the nearest clean water is far away from this village. Drinking polluted water can cause many types of diarrheal diseases including Cholera, Typhoid and Dysentery. Most of the family members suffered from these diseases. They cannot afford to buy a tube well as they don't enough money.

While the field work of Sylhet Jubo Academy (SJA) has visited to the house of Asma Begum. Once visiting her house and knowing their bad condition, SJA decided to provide them a tube well by the donor Penny Appeal from the project named 'Community Participated Safe Water Project installation of 700 STW'. After the installation of the tube well, all the family members drinking safe and clean water from this tube well and doing other works related to water.



Law Cost School Construction for the Disadvantaged Children of Tea Garden-Sylhet



Low-cost school buildings reduce the total amount of investment for the construction and facilitate to increase the number of schools especially in tea garden area. By using various methods and materials, to achieve low-cost school building in both economy and safety point of view.



The project title is Law Cost School Construction for the Disadvantaged Children of Tea Garden-Sylhet implemented by Sylhet Jubo Academy (SJA). To construct law cost school building and WatSan facilities at Tea Garden of Sylhet which contribute to improve the informal education of 100 numbers of disadvantaged children. The total duration of the project is three months. Starting November 1, 2017 and ended 31 January, 2018.

Construction Diagram / Preparation:

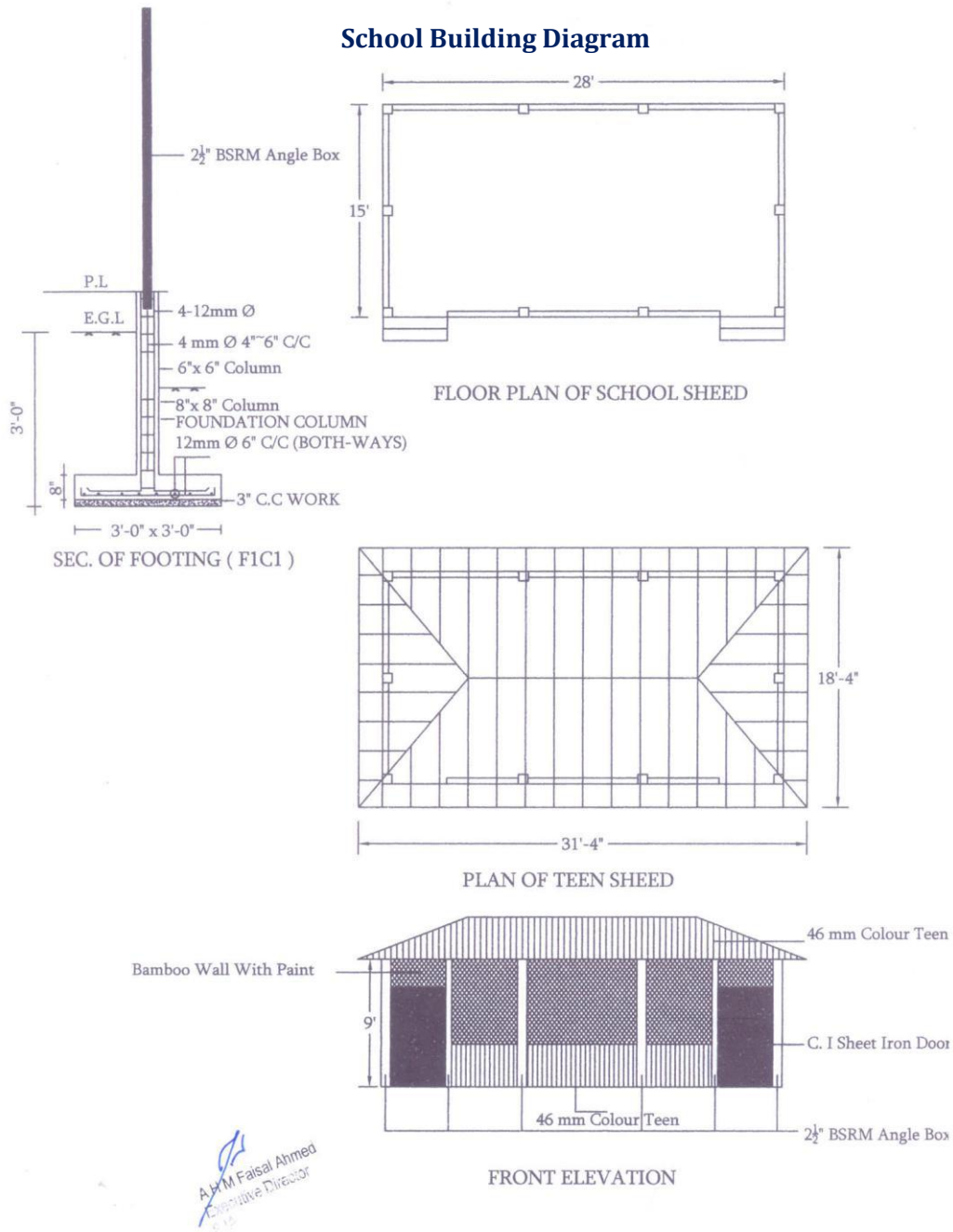

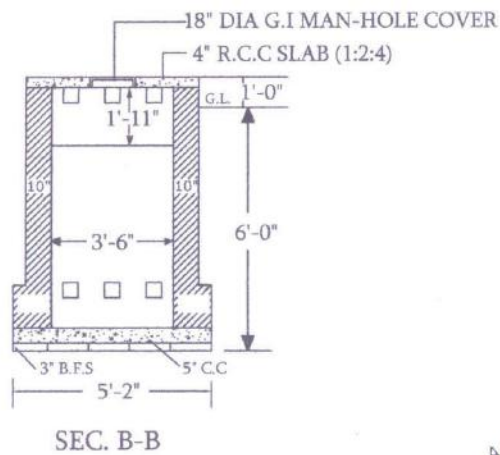
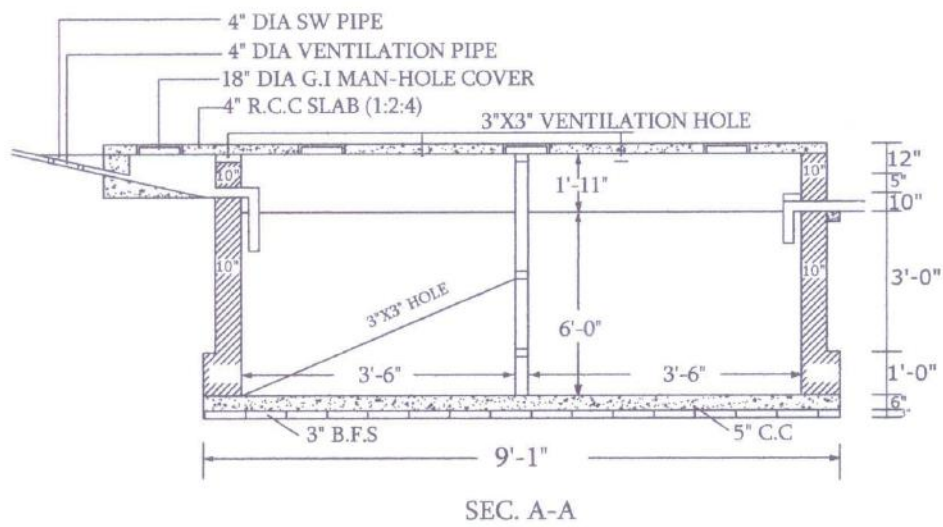
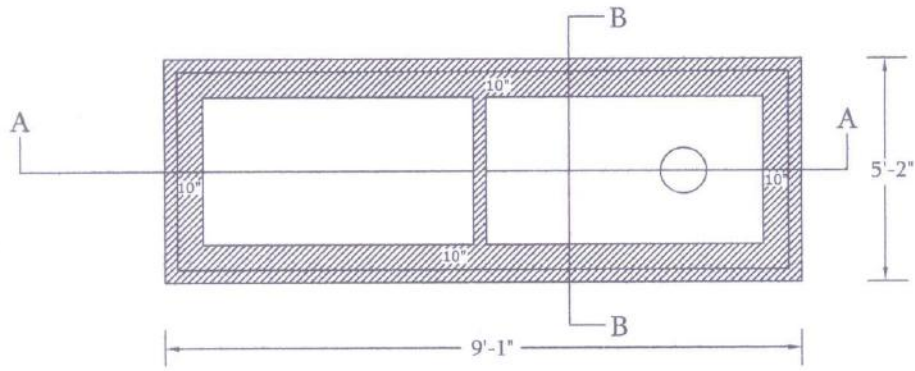

AHM Faisal Ahmed
 Executive Director
 S-15

- (a) 10 mmØ 4.5°c/c alt. ckd.
- (b) 10 mmØ 4.5°c/c alt. ckd.
- (c) 1-10mmØ Ex. Top
- (d) 1-10mmØ Ex. Top

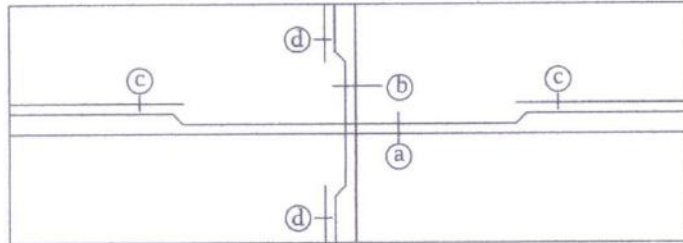

REINF. SEPTIC TANK SLAB (1:2:4)
SLAB THICKNESS = 5"

- (a) 10 mmØ 5°c/c alt. ckd.
- (b) 10 mmØ 5°c/c alt. ckd.
- (c) 1-10mmØ Ex. Top
- (d) 1-10mmØ Ex. Top

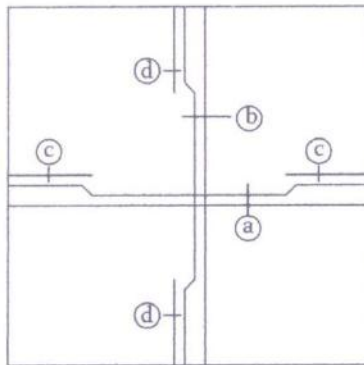

REINF. TOILET SLAB (1:2:4)
SLAB THICK=3"

A.H.M Faisal Ahmed
Executive Director

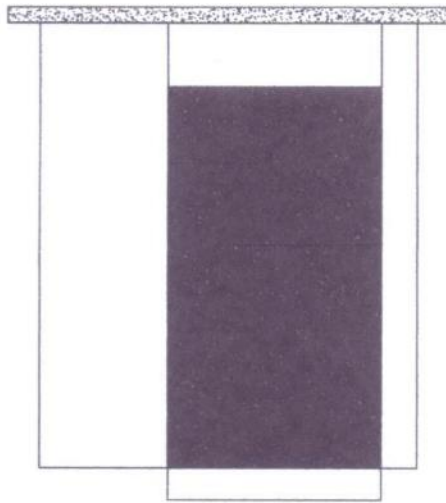

FRONT ELEVATION

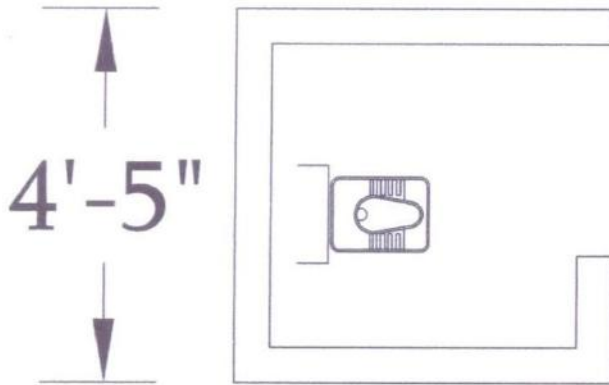

PLAN OF TOILET

AHM Faisal Ahmed
Executive Director
S.A.

Process followed for Project Implementation

- Organized meetings with local CBO KYAG, Tea Garden Community People and Management of Tea Garden for obtaining their opinion and choice;
- Site selection and finalize design/pattern of School, sanitary Toilet and Tube-Well with participatory practice along with the beneficiaries;
- Collect project approval from the respective government authority (NGO Affairs Bureau);
- Officially inform about the construction of low cost school project and Muslim Charity contribution to the Deputy Commissioner (DC) at district level and Upazila Nirbahi Officer (UNO) at upazila level;
- Maintained all through participatory planning and implementation from the beginning to end of the project;
- Respect and recognize the decision of beneficiaries (tea garden people) at all stages;
- Site visit and finalize design for construction of school and sanitary toilet by professional;
- Selection of Mason (for construction works) and carry on the works;
- Ensure quality of works and materials used for the construction as per diagram/design supplied by the professional (civil engineer) through regular supervision and monitoring by SJA staff-members and periodic visits by civil engineer;

Summary of Construction Works:

a) Construction of School Building

- Size of School : 28' X 15'
- Materials Used : Column BSRM steel
Roof made by CI sheet with iron frame
Roof Ceiling bamboo made ceiling under the CI sheet roof
Wall 3' height CI sheet wall at lower part and upper part Bamboo made
Floor CC with net finishing
Door CI sheet made

b) Construction of Sanitary Toilet

- Double chamber Septic Tank
- Room CC with bricks
- Door CI sheet made

c) Installation of Shallow Tube Well

- Depth 120'
- Platform 5'-0" × 5'-6"
- Sewerage line with CC channel and PVC pipe

Renovation Works of Sarampur Government Primary School-Rajnagar



The school renovation strategy is essential for making a replacement and creating a contemporary infrastructure that meets the needs of upgraded pedagogy by reshaping the learning spaces and making the construction innovative.

The project title is Renovation Works of Sarampur Government Primary Schools-Rajnagar. The duration of the project is five months from the inception date. This project has been undertaken in view of the extreme hardship of govt. Primary schools of rural and hard-to-reach area of Moulvibazar district under Sylhet division. Sarampur Govt. Primary School building was in hazardous conditions that are not permissible for child safety and quality education, during rain & hot time mostly classes terminated/cancelled. Respective primary school children are facing serious difficulties and live risks of their regular classes at that primary school. Even teachers are also facing similar problems which make them facing problems to their teaching and as a result quality of education is low; student's absence rate is higher, health hazard raising morbidity rate among the rural children.

Sarampur Govt. Primary School: 4 rooms consist of this school building roof made by CI sheet/Tin and the whole roofs are broken down, floors are broken, all class-rooms are damp and ethically this is not allowable for conducting classes for children's. Core improvements are in the following:

- Ensure an uninterrupted favorable/positive learning atmosphere for the children of mainstream primary education of rural community/areas to ensure sustainable quality education at grassroots.
- Number of 200 children's of Sarampur primary school attending regular classes with
- healthy and friendly class rooms facilities after of renovation works of the school;
- Reduced morbidity rate and improve health system of the rural children;
- Ensured security and improve life standard of 200 children of the school
- Number of student enrolment will be increased;
- Quality of Government services and their accountability improved.
- Renovation of School Building
- Built a new Toilet
- Repairing of Students desk and bench
- Installation of Deep tube-well
- Provide 6 nos of Water Filters along with stand
- Prior program designing an assessment done with school teachers and SMC members of respective school.
- The whole renovation works done according to the desire of SMC members and teachers of respective School.

Based on the total programme for this period, there are 200+ children directly and approximately 1000+ children were indirectly benefited.

Through this renovation works a healthy children friendly environment has been created for the children of the backward community and through which the dropout rate will be reduced and numbers of new enrollment will be ensured. Approximately 140 + girls children of this primary school are benefited and in coming days a good numbers of new girl children will be enrolled in the school for primary education.

Here a couple of photos from the renovation project:



Photo: Before and after scenario of Sarampur Government Primary School.

For such types of renovation works mostly found quite difficult to keep the works as per plan of prior need assessment. Because while after starting of implementation of the old building the works volumes increase basis of situation and demand of respective school management. For this project, when we started the renovation works then we have seen

that the expenditure of repairing and renovation works are exceeds from the approved budget but due to commitment of SJA to maintain the quality intervention we straight away utilize the budget line item which allocated for Dhaka travel, Plaque/Sign, and Overhead cost by shifting to the program cost. And for this as a result SJA are not able to charge these costs in this project.

In future for implementation of such types of project there should be keep some of amount as provision in a contingency budget line head and if there are any situation arise with the prior approval of donor this amount will be utilize with proper justification.

Through this renovation works a healthily children friendly environment has been created for the children of the backward community and through which the dropout rate will be reduced and numbers of new enrollment will be ensured.

In addition, a clear concept grown among the community people and government authority on MC-UK and its charity works for the deprived people of Bangladesh which obviously create a positive image of MC-UK.

To keep the renovation works on right-track and to ensure quality implementation Sylhet Jubo Academy (SJA) has assigned a good number of its staffs to monitor the renovation works. Besides this from the Senior Management of SJA including Executive Director made frequent visits to the site and gave appropriate guidance for quality works.

To ensure the quality implementation there are also another monitoring bodies forms consists of the Chairperson and Member of School Management committee and SJA senior level staffs to monitor jointly the renovation works and its quality.

Also, from MC-UK Bangladesh country office the representatives visit the renovation works and provides his feedback.

Since the beginning potential stakeholders like elected representatives, local elites, religious leader, youths and the teachers & SMC members are involved of whole process from starting to end. As we have renovated the school so it's ensured an uninterrupted favorable learning atmosphere for the children of mainstream primary education of rural area to ensure sustainable quality education at grassroots. Students of Sarampur primary school attending regular classes with healthy and friendly class room facilities because of renovation works of the school. It has ensured security and improve life standard of 200 students of the school. As a result the morbidity rate will be reduced and the health system of the students will be improved. The number of student enrolment will be increased and the quality of Government services and their accountability improved.



Low Cost School Construction-Gowaipara



School is a basic need of education which indeed results in the development of the country. The low-cost school infrastructure will include the provision of facilities such as decorated classrooms, outdoor learning and a peaceful environment.

Project Summary

The children of Slam area in Bangladesh do not have adequate access to education, health services and employment opportunities. Sylhet city slum's living condition is very much worse and overcrowded from different domestic location.

To improve their human dignity and living condition, educational support is more prioritized need for them.

Project Implementation

- Organized meetings with Gowaipara Community People and Member of ward for obtaining their opinion and choice.
- Site selection and finalize design/pattern of Pre- primary school with participatory practice along with the beneficiaries.
- Collect project approval from the respective government authority (NGO Affairs Bureau).
- Officially inform about the construction of low cost school project and Friends of Khasdobir-UK contribution to the Deputy Commissioner (DC) at district level and Upazila Nirbahi Officer (UNO) at upazila level.
- Maintained all through participatory planning and implementation from the beginning to end of the project.
- Respect and recognize the decision of beneficiaries (Gowaipara Community People) at all stages.
- Site visit and finalize design for construction of school;
- Selection of Mason (for construction works) and carry on the works;
- Ensure quality of works and materials used for the construction as per diagram/design supplied by the professional (civil engineer) through regular supervision and monitoring by SJA staff-members and periodic visits by civil engineer.
- The duration of the project is 20 March 2018 to 20 September 2018

Summary of Construction Works:

Construction of School Building

- Size of School : 28' X 13'

- Materials Used : Column BSRM steel

Roof made by CI sheet with iron frame.

Roof Ceiling bamboo made ceiling under the CI sheet roof

Wall 3' height CI sheet wall at lower part and upper part bamboo made.

Floor CC with net finishing.

Door CI sheet made

LOW COST SCHOOL - GOWAIPARA , SYLHET.
Funded by: Friends of KHASDOBIR - UK
Implemented by : Sylhet Jubo Academy.

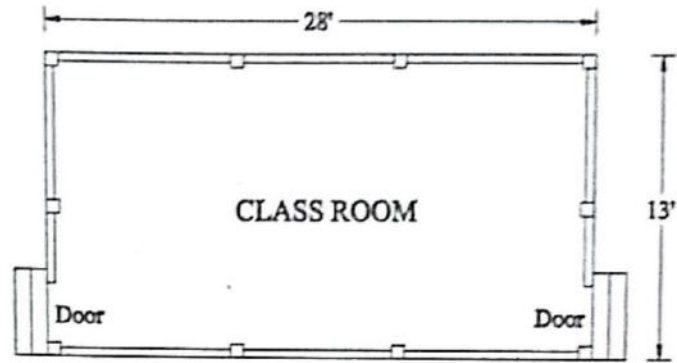

FLOOR PLAN OF SCHOOL SHEED

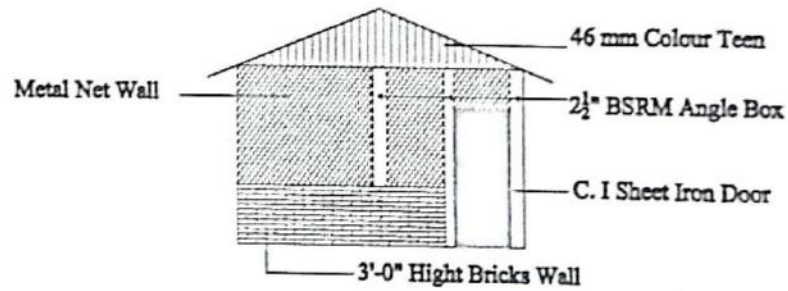

FRONT ELEVATION

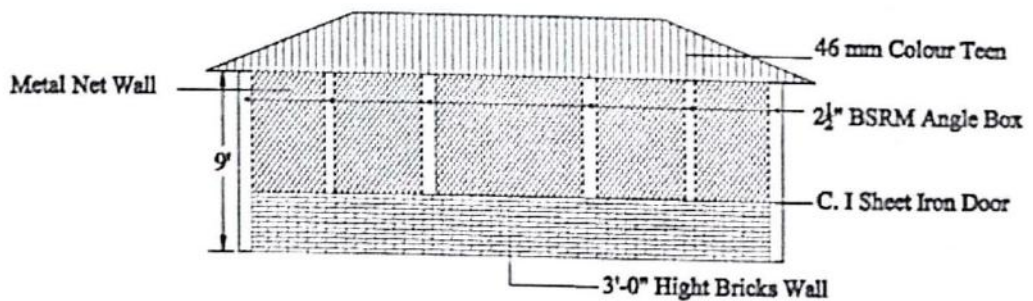

SIDE ELEVATION

LOW COST SCHOOL - GOWAIPARA , SYLHET.
 Funded by: Friends of KHASDOBIR - UK
 Implemented by : Sylhet Jubo Academy.

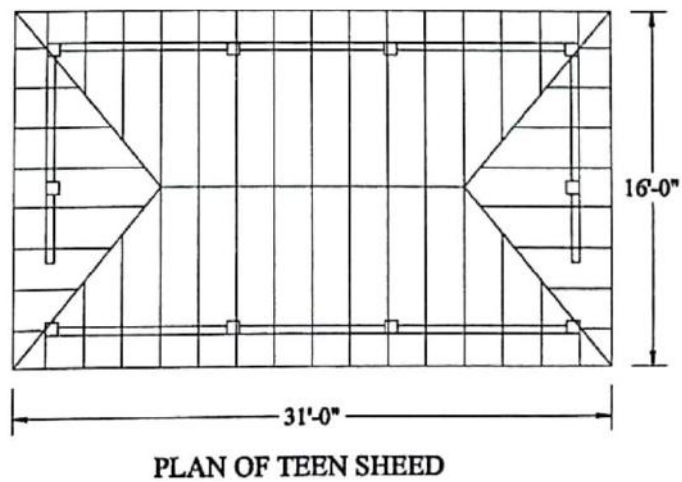
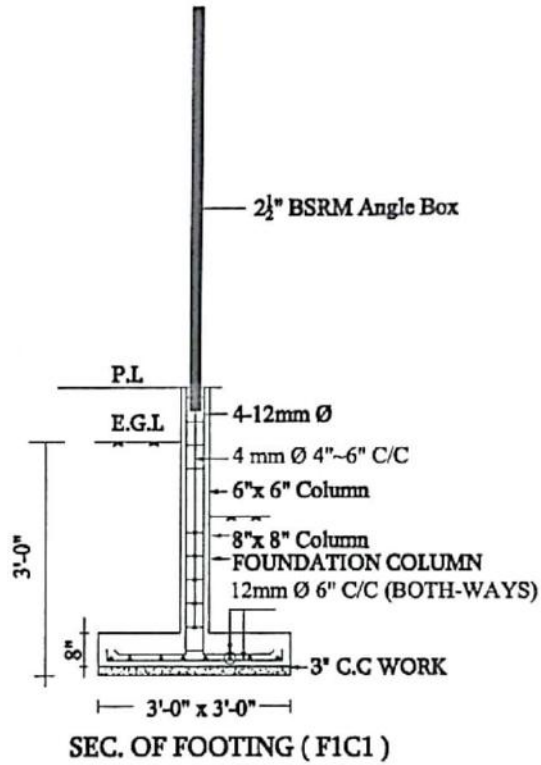



Sylhet Jubo Academy (SJA)

House # 09, Road # 04, Block - A, Shahjalal Uposhahar, Sylhet-3100, Bangladesh.

Tel: +880 821 761546, Mobile: +880 1707-074737

Email: info@sjabd.org, Website: www.sjabd.org

Facebook: facebook.com/sjabd.org